

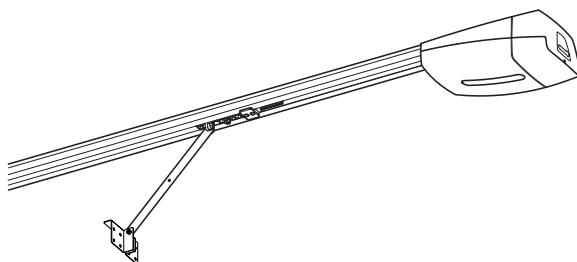

**Garage-door operator
VER-PLUS series**

FA01358-EN



VER10DMS-VER13DMS

INSTALLATION MANUAL

EN English

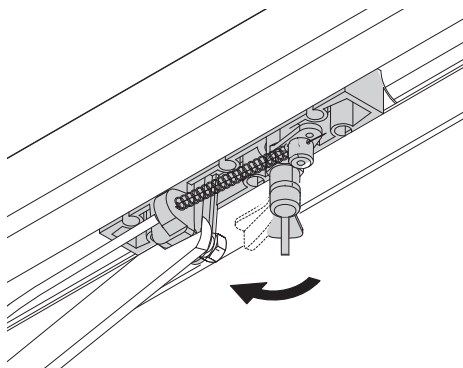
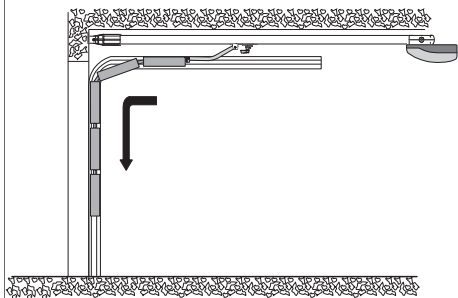
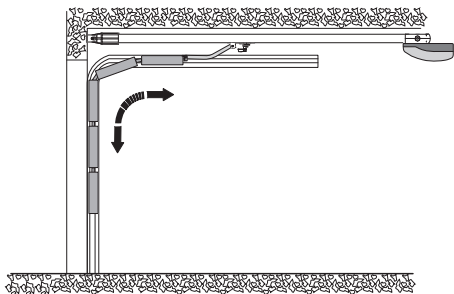
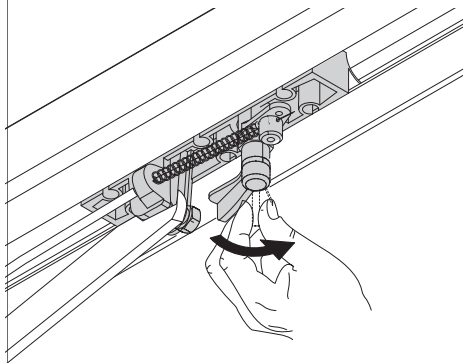

GENERAL PRECAUTIONS FOR INSTALLERS

⚠ CAUTION! Important safety instructions.

Follow all of these instructions. Improper installation can cause serious bodily harm. Before continuing, also read the general precautions for users.



This product must only be used for its specifically intended purpose. Any other use is dangerous. Came S.P.A. is not liable for any damage caused by improper, wrongful and unreasonable use. • This manual's product is defined by machinery directive 2006/42/CE as "partly-completed machinery". Partly-completed machinery is a set that almost constitutes a machine, but which, alone, cannot ensure a clearly defined application. Partly-completed machinery is only destined to be incorporated or assembled to other machinery or other partly-completed machinery or apparatuses to build machinery that is regulated by Directive 2006/42/CE. The final installation must be compliant with European directive 2006/42/CE and current European reference standards • Given these considerations, all procedures stated in this manual must be exclusively performed by expert, qualified staff. • Laying the cables, installation and testing must follow state-of-the-art procedures as dictated by regulations • Before installing the operator, check that the door is in proper mechanical condition, that it is properly balanced and that it properly closes: if any of these conditions are not met, do not continue before having met all safety requirements • Make sure that opening and closing limiters are fitted • Make sure the operator is installed onto a sturdy surface that is protected from any collisions • Make sure that mechanical stops are already installed • If the operator is installed lower than 2.5 from the ground or from any other access level, fit any protections and signs to prevent hazardous situations. • Do not fit the operator upside down or onto elements that could yield to its weight. If necessary, add reinforcements to the fastening points • Do not install unless door is level to the ground • Suitably section off and demarcate the entire installation site to prevent unauthorized persons from entering the area, especially minors and children. • Affix cautionary signs, such as the door plate, wherever needed and in plain sight • Use proper protections to prevent mechanical hazards when people are loitering around the machinery's range of action, for example, avoid finger crushing hazards between the drive arm and the mechanical stops when the door is opening, and so on). • The electrical cables must run through the cable glands and must not touch any parts that may heat up during operation, such as the motor, transformer, and so on). • All opening controls must be installed at least 1.85 m from the perimeter of the garage door's working area, or where they cannot be reached from outside the door. • All switches in maintained-action mode must be positioned so that the door, the transit areas and vehicle thru-ways are completely visible, and yet the switches must be also away from any moving parts • Unless the action is key operated, the control devices must be fitted, at least, 1.5 m from the ground and where they are not accessible to unauthorised persons • Before handing over to users, check that the system is compliant with the 2006/42/CE uniformed Machinery Directive. Make sure the settings on the operator are all suitable and that any safety and protection devices, and also the manual release, work properly. • Affix a permanent tag, that describes how to use the manual release mechanism, close to the mechanism. • Make sure to hand over to the end user, all operating manuals for

the products that make up the final machinery • set up a suitable dual pole cut off device along the power supply that is compliant with the installation rules. It should completely cut off the power supply according to category III surcharge conditions • The gear motor must be only powered by very low safety voltage, which corresponds to what is stated in the markings on the gear motor • Keep the section of this manual inside the technical folder along with the manuals of all the other devices used for your automation system. Remember to hand over to the end users all the operating manuals of the products that make up the final machinery.

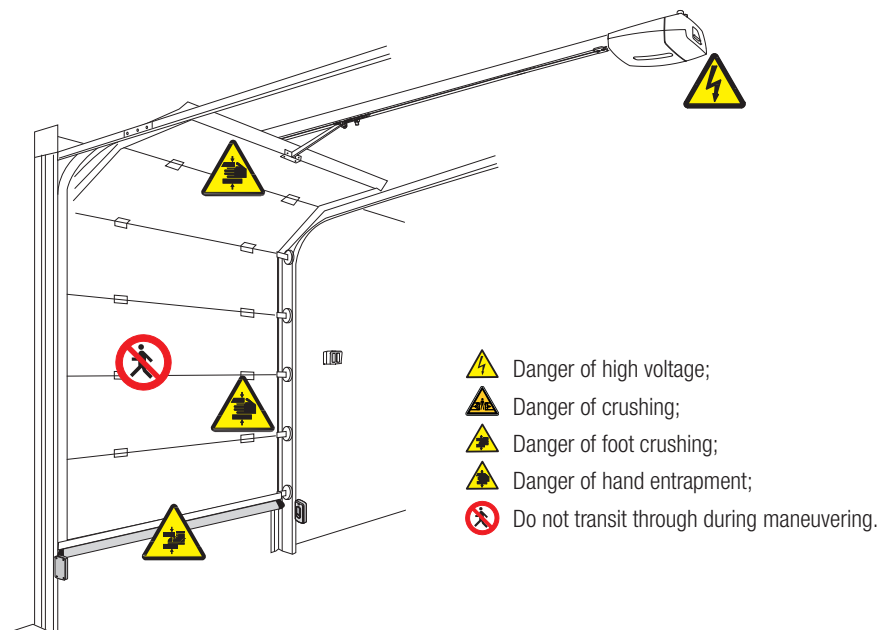
The next figure shows the main hazard points for people.



KEY

-  This symbol shows which parts to read carefully.
-  This symbol shows which parts describe safety issues
-  This symbol shows which parts to tell users about.

The measurements, unless otherwise stated, are in millimeters.

DESCRIPTION

Automated operator featuring a control panel with encoder for sectional and overhead garage doors.

Intended use

The VER10DMS / VER13DMS operators are developed to drive overhead and sectional garage-doors in private homes and apartment buildings.

-  Do not install or use this device in any way, except as specified in this manual.

Limits to use

Type	VER10DMS	VER13DMS
Door's max. surface area (m ²)	18	21
Counter-weighted overhead door's max. weight (m)		2.40
Maximum height of spring-balanced overhead doors (m)		3.25
Maximum height of sectional doors (m)		3.20

Technical data

Type	VER10DMS	VER13DMS
Protection rating (IP)		40
Power supply (V - 50/60 Hz)		230 AC
Input voltage motor (V)		24 DC
Stand-by consumption (W)	5	7
Stand-by consumption RGP1 (W)		0.5
Maximum power of the accessories (W)		40
Maximum power (W)	180	280
Maneuvering speed (m/min)		7
Traction force (N)	1,000	1.300
Acoustic pressure LpA (dBA)		≤70
Cycles/hour		30
Operating temperature (°C)		-20 to +55
Apparatus class		
Weight (Kg)	5.7	5.8

Dimensions

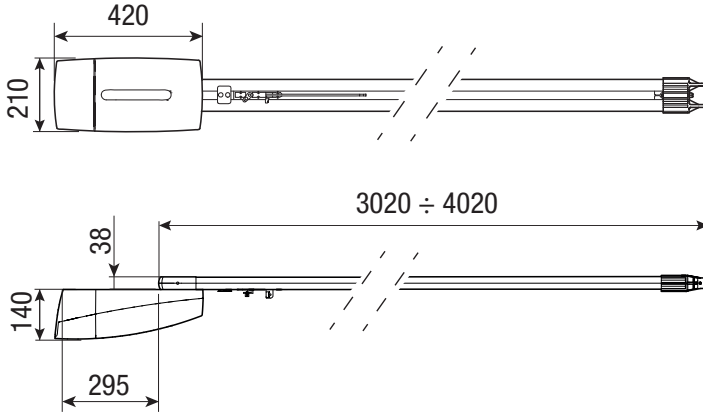

Description of parts

Operator

1. Cover
2. Gear motor
3. Transformer
4. Control board
5. Operator configuration buttons
6. Standard drive arm for the VER10DMS*
7. Standard drive arm for the VER13DMS*
8. Door fastening brace
9. Guide fastening brace
10. Ceiling fastening brackets
11. Cable gland
12. Fastening screws
13. Cover fastening hinge
14. Courtesy light

 (*) Only for sectional doors.

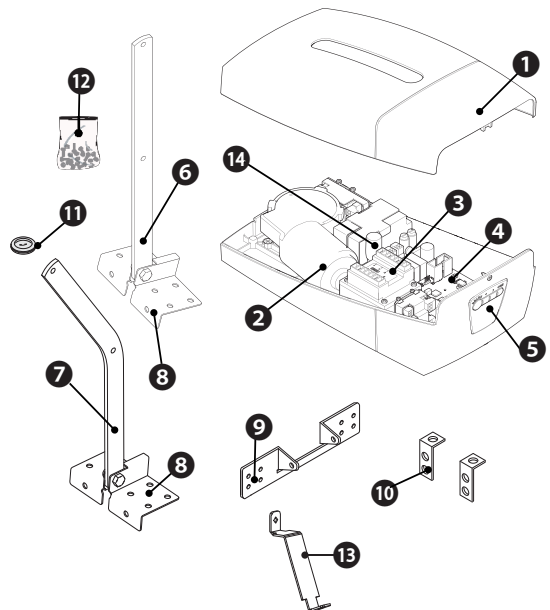

Guide

1. Guide
2. Chain or belt
3. Sliding guide with release tab
4. Mechanical stop
5. Support rods

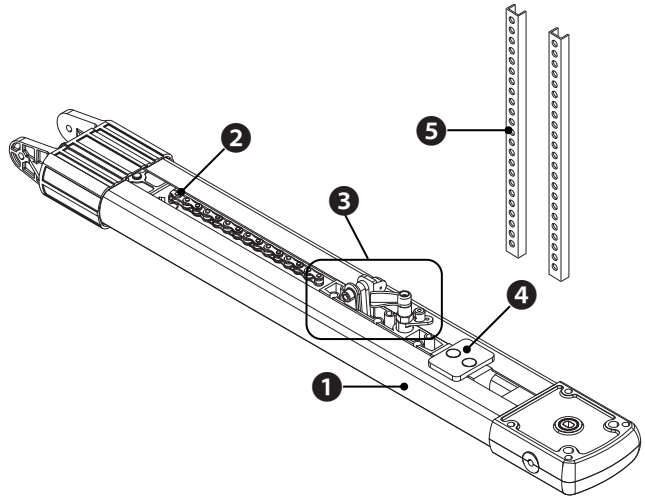

Chain drive

001V0679	Chain guide L = 3.02 m. Counter-balanced overhead doors up to 2.4 m in height - Counter-balanced overhead doors up to 2.25 m in height - Sectional* doors up to 2.20 m in height.
001V0682	Chain drive L = 3.52 m. - Counter-balanced overhead doors up to 2.75 m in height. - Sectional* doors up to 2.70 m in height.
001V0683	Chain drive L = 4.02 m in one piece. - Spring-balanced overhead doors up to 3.25 m in height. - Sectional* doors up to 3.20 m in height.
001V0684	Chain drive L = 3.02 m in two pieces. Counter-balanced overhead doors up to 2.4 m in height - Counter-balanced overhead doors up to 2.25 m in height - Sectional* doors up to 2.20 m in height.

Belt drive

001V0685	Belt drive L = 3.02 m. Counter-balanced overhead doors up to 2.4 m in height - Counter-balanced overhead doors up to 2.25 m in height - Sectional* doors up to 2.20 m in height.
001V0686	Belt drive L = 3.52 m. - Counter-balanced overhead doors up to 2.75 m in height. - Sectional* doors up to 2.70 m in height.
001V0687	Chain guide L = 3.02 in two pieces. Counter-balanced overhead doors up to 2.4 m in height - Counter-balanced overhead doors up to 2.25 m in height - Sectional* doors up to 2.20 m in height.
001V0688	Belt drive L = 4.02 m. - Spring-balanced overhead doors up to 3.25 m in height - Sectional* doors up to 3.20 m in height.

Accessories

001V005	Extension for the following types of chain guides: V0679, V0682, V0683, V0684.
001V201	Transmission arm for partially retracting overhead garage-doors.
001V122	Transmission arm for sectional doors having a top-rail to spring-pole assembly distance comprised between 300 and 600 mm.
001V121	Pull-cord auto-resetting release device to fit onto the door handle.
801XC-0010	Emergency card for operating during power outages, with batteries.

Applicative examples

SECTIONAL DOOR

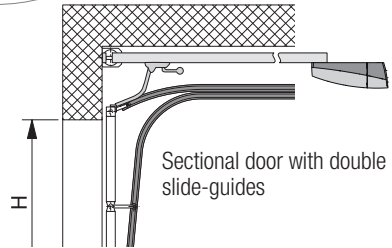
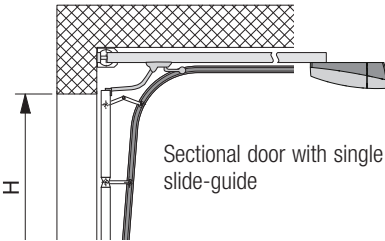
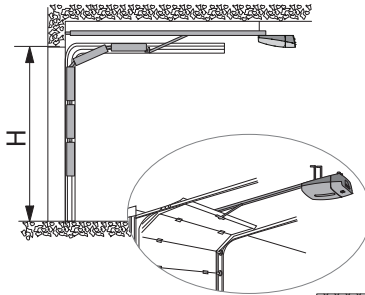

COUNTER-BALANCED, PROTRUDING AND PARTIALLY RETRACTING

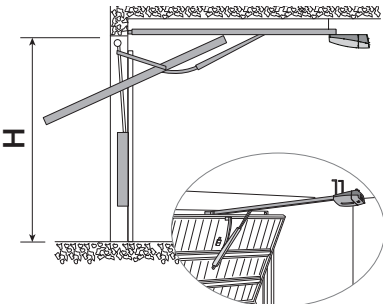

SPRING-BALANCED, PROTRUDING AND PARTIALLY RETRACTING

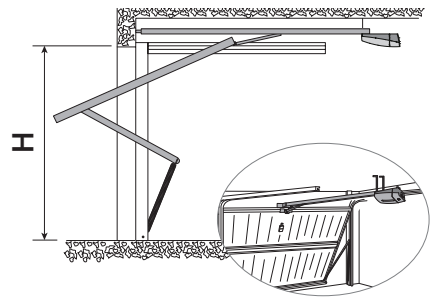

Standard installation

1. Operator
2. Guide
3. Release device
4. Transmission arm
5. Key-switch selector
6. Photocells
7. Control device
8. Sensitive safety-edge
9. Flashing light and antenna

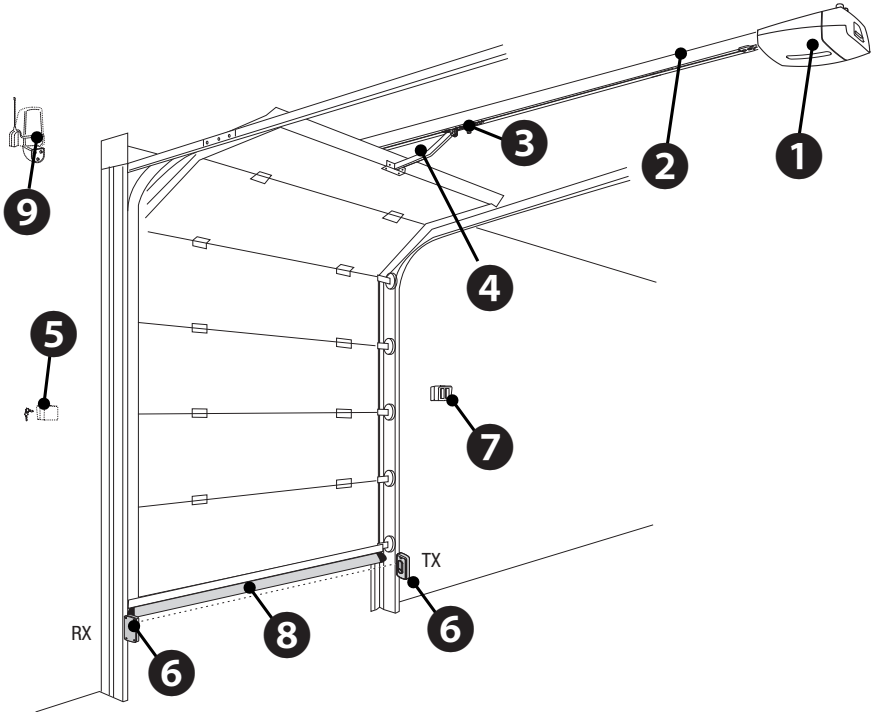

GENERAL INSTALLATION INDICATIONS

△ Only skilled, qualified staff must install this product.

Cable type and minimum thicknesses

Connection	cable length	
	< 20 m	20 < 30 m
Control panel power supply 230 V AC	3G x 1.5 mm ²	3G x 2.5 mm ²
Flashing light	2 x 0.5 mm ²	
Command and control devices	2 x 0.5 mm ²	
TX Photocells	2 x 0.5 mm ²	
RX photocells	4 x 0.5 mm ²	

📖 When operating at 230 V and outdoors, use H05RN-F-type cables that are 60245 IEC 57 (IEC) compliant; whereas indoors, use H05VV-F-type cables that are 60227 IEC 53 (IEC) compliant. For power supplies up to 48 V, you can use FROR 20-22 II-type cables that comply with EN 50267-2-1 (CEI).

📖 To connect the antenna, use the RG58 (we suggest up to 5 m).

📖 For paired connection and CRP, use a UTP CAT5-type cable (up to 1,000 m long).

📖 If cable lengths differ from those specified in the table, establish the cable sections depending on the actual power draw of the connected devices and according to the provisions of regulation CEI EN 60204-1.

📖 For multiple, sequential loads along the same line, the dimensions on the table need to be recalculated according to the actual power draw and distances. For connecting products that are not contemplated in this manual, see the literature accompanying said products

INSTALLATION

△ Only skilled, qualified staff must install this product.

△ The following illustrations are mere examples in that the space for fastening the operator and accessories varies depending on the installation area. It is up to the fitter, therefore, to choose the most suitable solution.

Assembling the guide

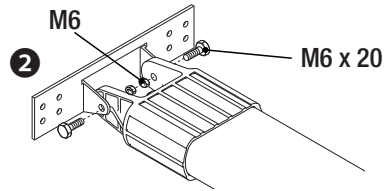
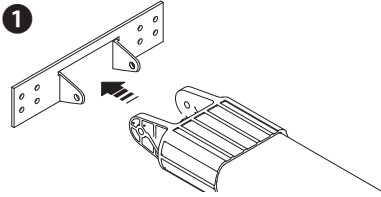

Positioning the guide

Sectional doors: above the spring-pole brace assembly. If the distance between the spring-pole and the upper part of the door is between 300 mm and 600 mm, use the V122 transmission arm.

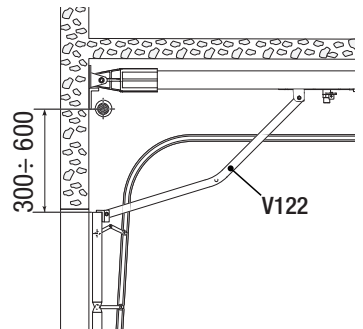
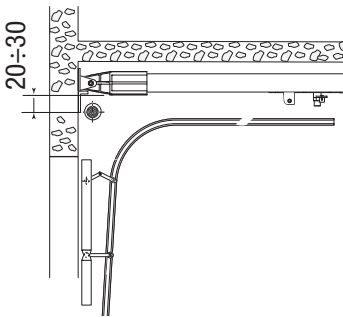

For protracting overhead doors, keep the guide 20 mm from the opening high-point.

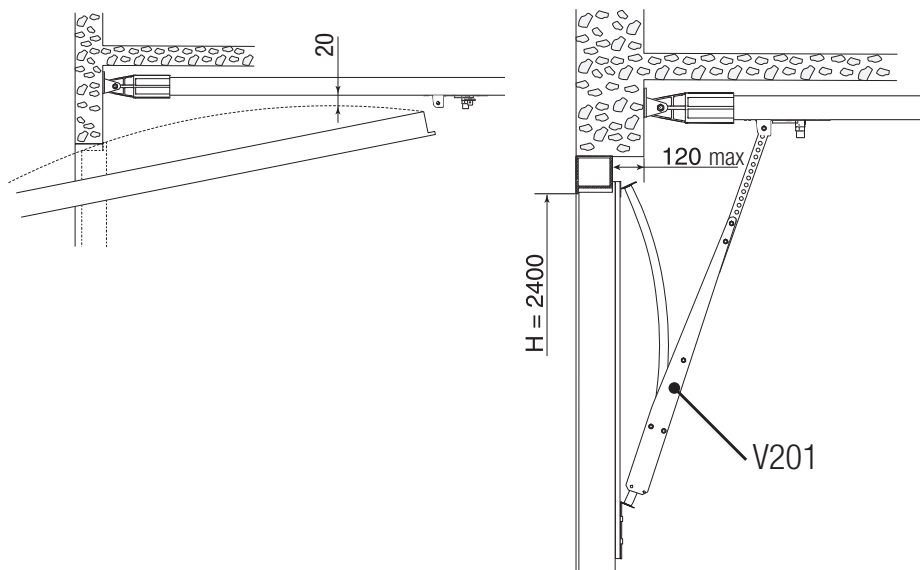

☞ For protracting, partially retracting overhead doors, use the V201 transmission arm (optional accessory).

Fastening the cover

Fasten the hinge to the cover by using the supplied screws ❶. Fit the cover onto the operator ❷.

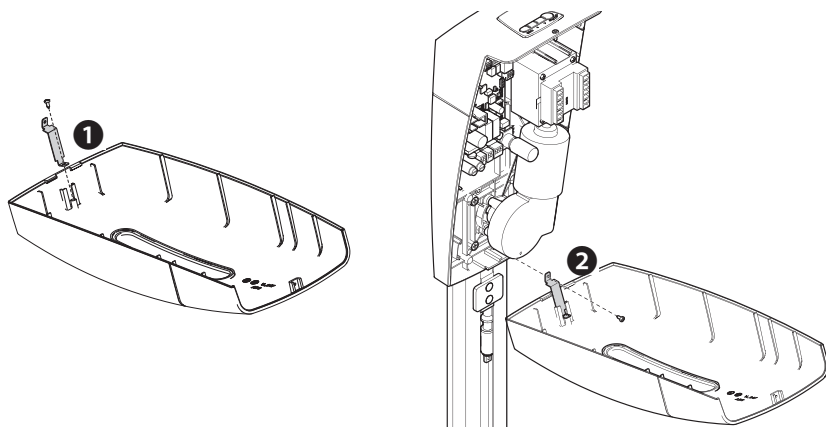

Fastening the guide-shaft

1. Fasten the guide-shaft to the center of the door opening. Use suitable bolts.
2. Raise the guide-shaft and position it horizontally to measure the distance from the ceiling, and then fasten it.

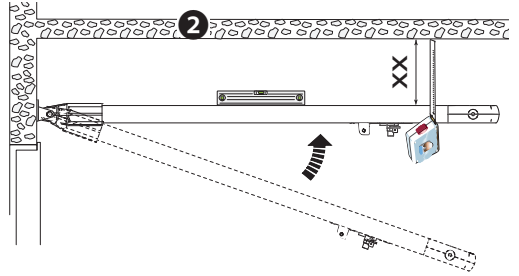
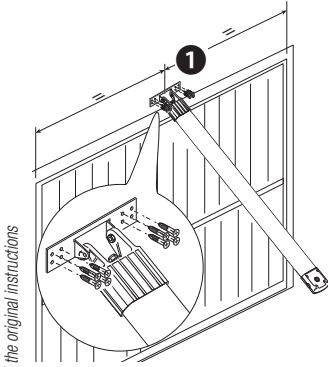

- Fasten the braces to the guide and directly to the ceiling or use the supplied extensions and adapt them to the required height.
3. If necessary, fit additional support rods.
- Use suitable screws and dowels.

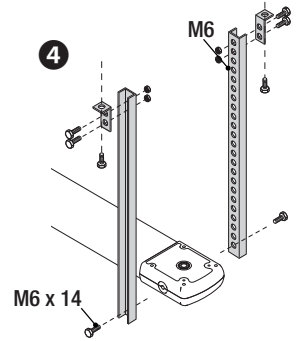
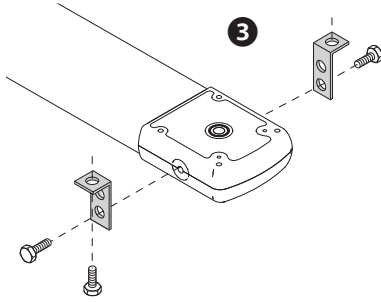

Turn the release tab counter-clockwise **5**.
 Move the traction assembly towards the door **6** and fasten the transmission arm using the supplied bolt **7**.

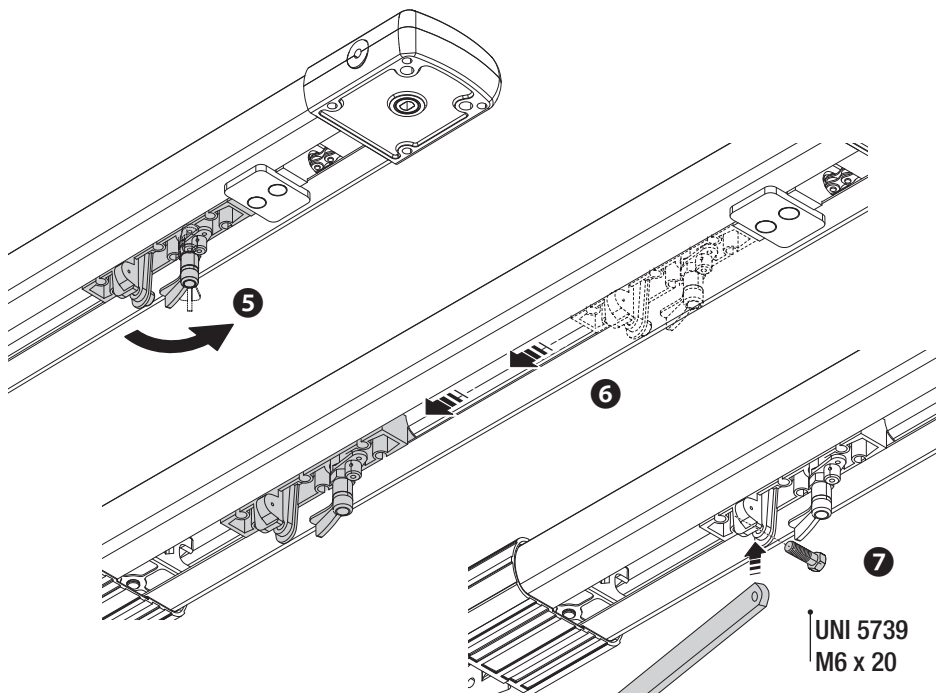

Fitting the operator to the guide

Fasten the operator to the guide-shaft by using the supplied screws **1**.

 The operator can also be fitted laterally **2**.

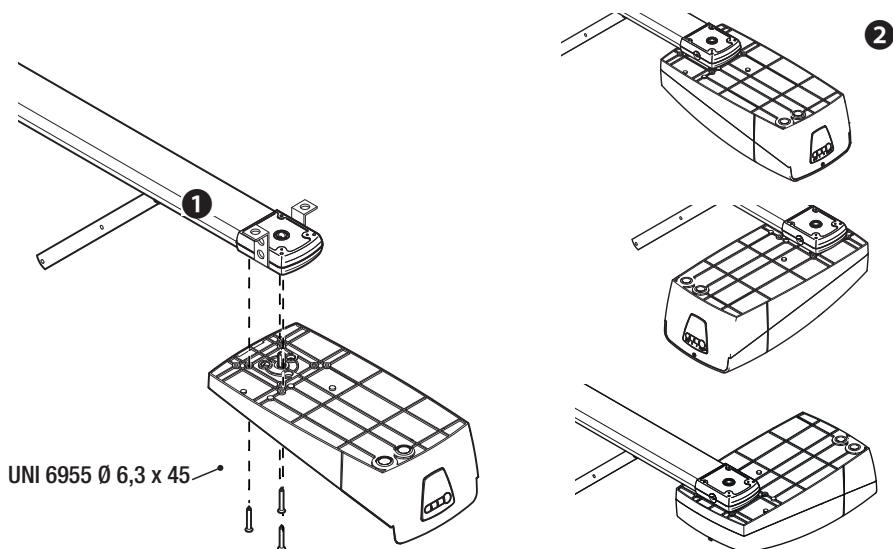

Perforate the cable gland **3** run the cables through **4** and fit the cable gland into its brace **5**.

 The number of cables depends on the type of system and accessories fitted.

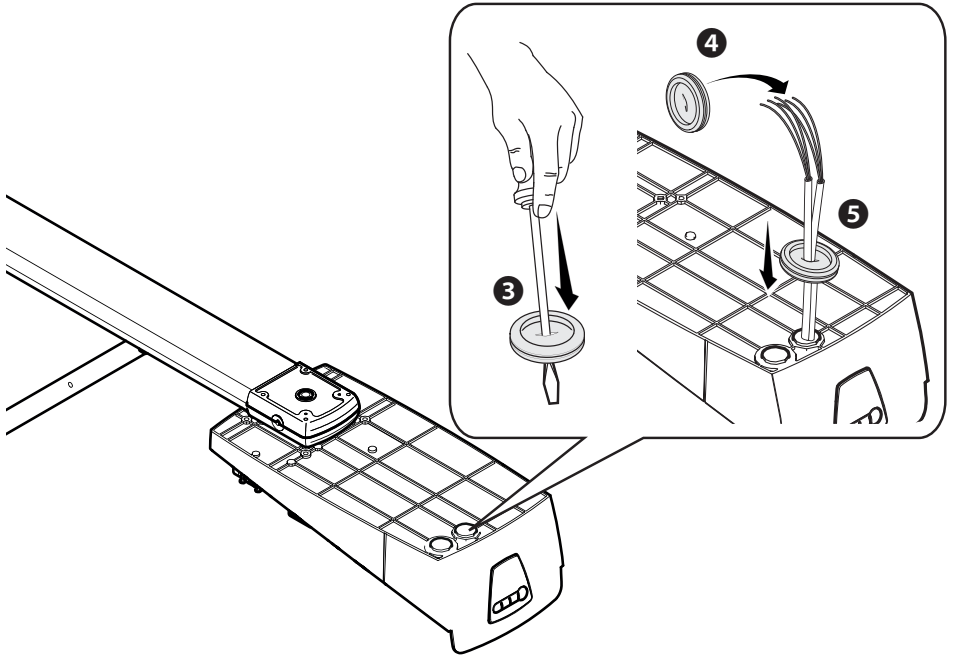

ELECTRICAL CONNECTIONS AND PROGRAMMING

⚠ Before doing any work on the control board, cut off the mains power supply, and disconnect any batteries.
Power supply to the control board and control devices : 24 V AC/ DC.

Functions on the input and output contacts, time adjustments and user-management settings are set and viewed on the control board's display.

All connections are fuse-protected.

Fuses	ZL57
Line	630 mA T (230 V)
Motor	8 A-T
Accessories	2 A-F

Courtesy light	
Technology	LEDs
Power supply (V)	24 DC
Plug	E14
Consumption (W)	1

Description of parts

1. Courtesy light
2. Encoder terminal board
3. Gear motor terminal board
4. Control board terminal board
5. Accessories fuse
6. Motor fuse
7. Connector for Came Key
 - It excludes remote connection with CRP.
8. Programming warning LED
9. Connector for R700/R800 card
10. AF card connector
11. Terminal board for keypad devices
12. Antenna terminals
13. Connector for the DPT01 programming card
14. Terminal board for transponder selector
15. CRP connection terminals
16. RSE card connector
 - It excludes local connection with Came Key.
17. Terminal board for control and safety devices
18. Terminal board for warning devices
19. Memory Roll card connector
20. RGP1 module terminal
21. Connector for the RIOCN8WS card
22. Power supply on warning LED
23. Line fuse
24. Connector for the mains power-supply
25. DPT01 programming card
26. Display
27. Not used
28. Connector for connecting to the control board
29. Programming buttons

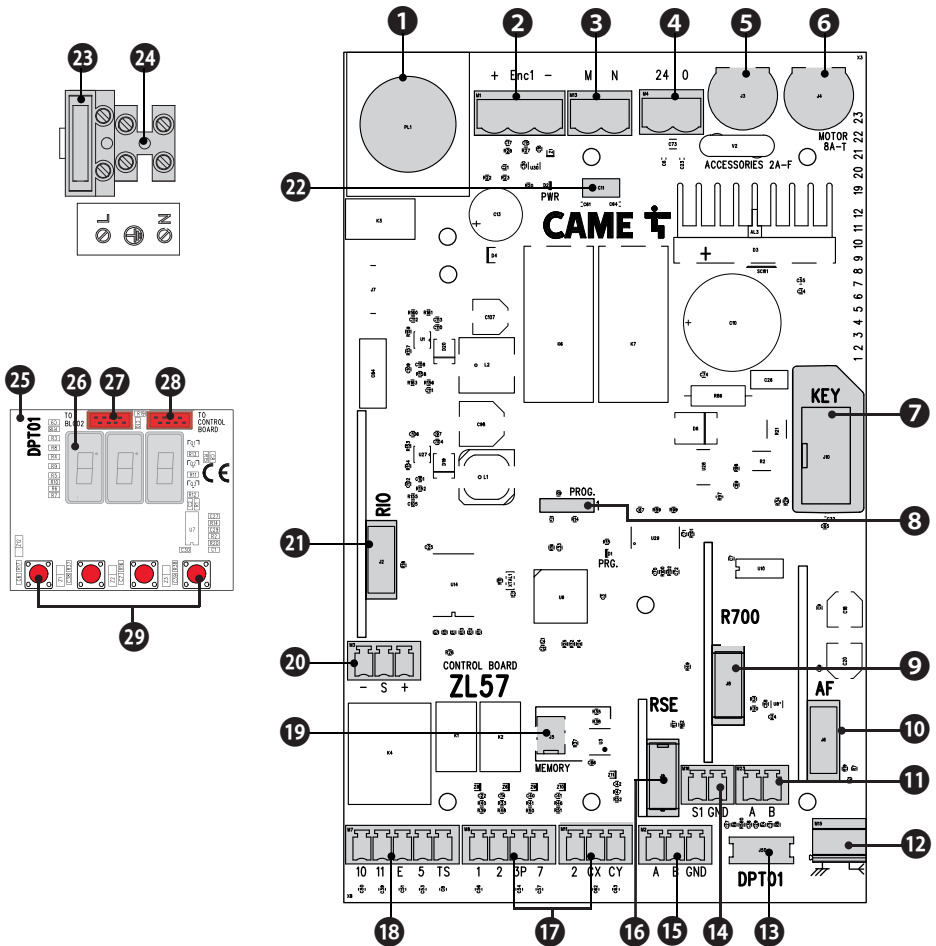

Input voltage

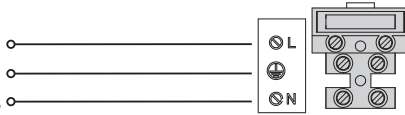

230 V AC - 50/60 Hz

Ref.	Description
(L)	HD Analog
(GND)	Ground
(N)	Neutral

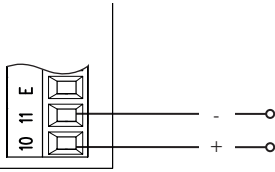

Accessories power supply output 24 V AC/DC, max 20 W

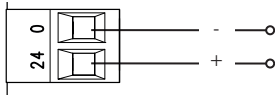

24 V AC/DC control board power-supply input

Factory wiring

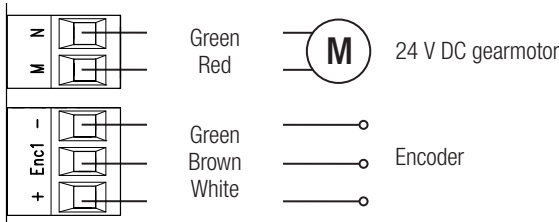

Signaling devices

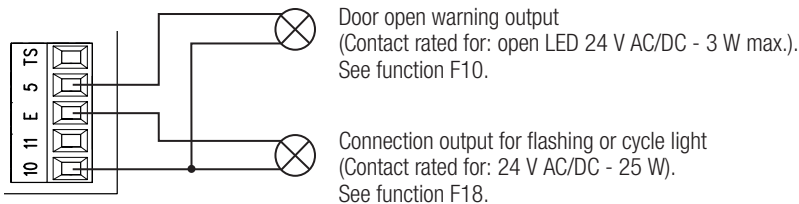

Absorption by all accessories: max. 40 W.

Command and control devices

⚠ For the system to work properly, before fitting any plug-in card, such as the AF or R800 one, you MUST CUT OFF THE MAINS POWER SUPPLY and, if present, disconnect any batteries.

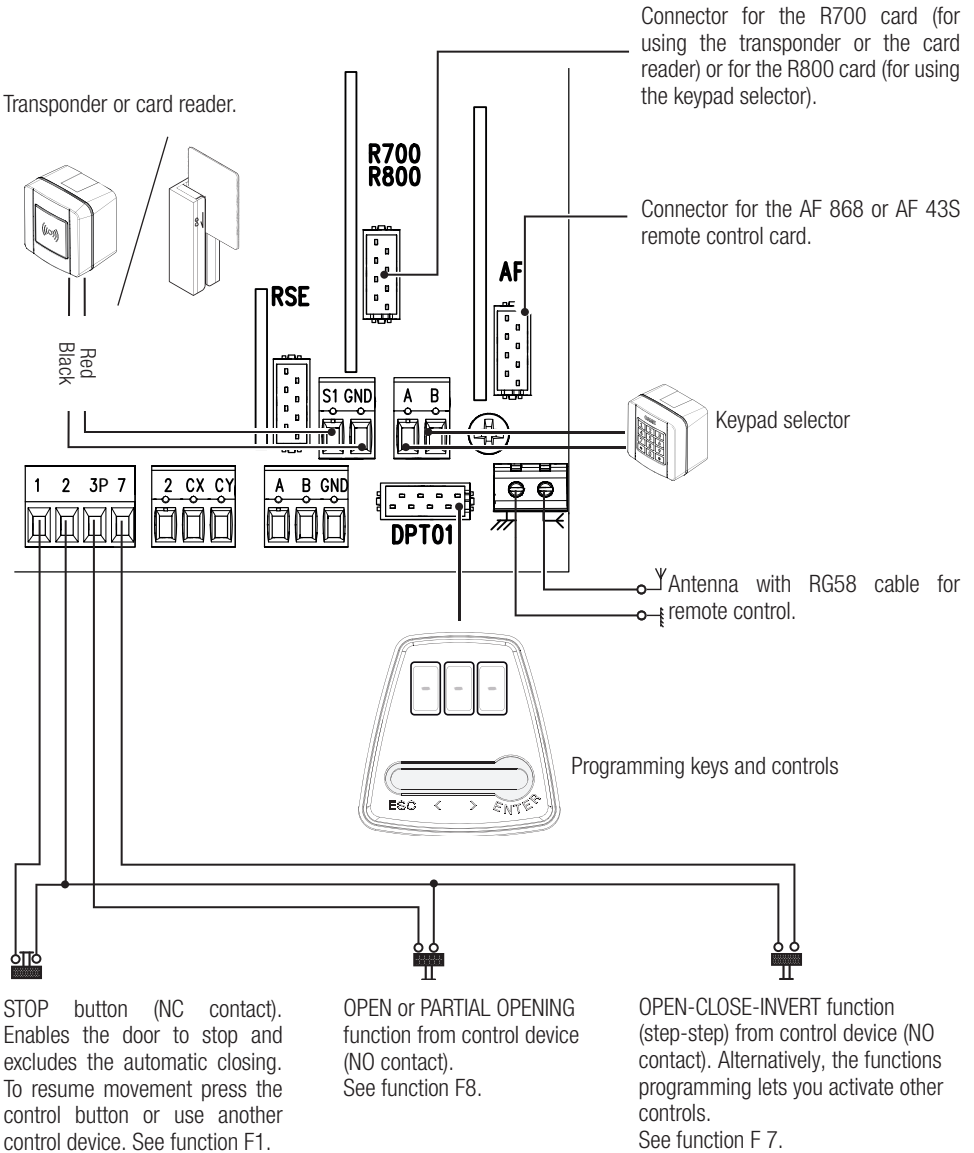

Safety devices

Photocells

Configure contact CX or CY (NC), safety input for photocells.

See CX input functions (Function F 2) or CY (Function F 3) in:

- C1 reopening during closing. When the door is closing, opening the contact causes the door to invert its movement until it is completely open.
- C2 close back up during opening. When the door is opening, opening the contact causes the door to invert its movement until it is completely closed.
- C3 partial stop. Stop door, if it is moving, with consequent automatic closing (if the automatic closing function is on);
- C4 obstruction wait. Stop door, if it is moving, which resumes movement once the obstruction is removed.

 If unused, contacts CX and CY should be deactivated during programming.

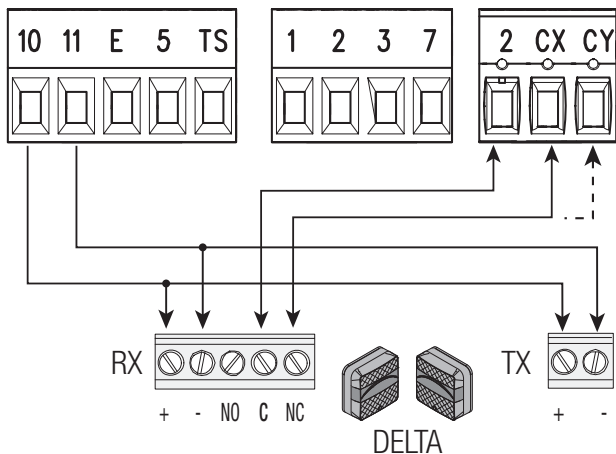
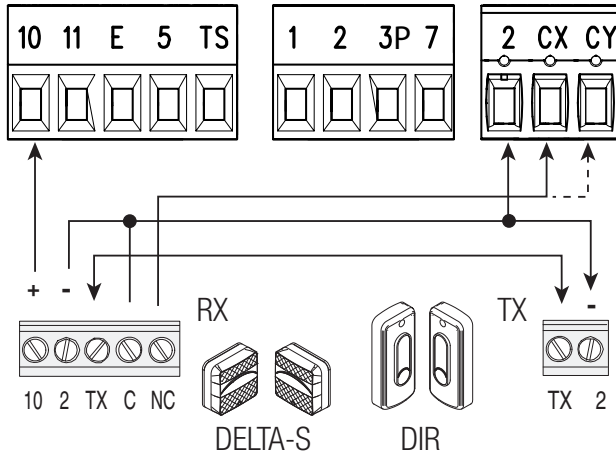

Sensitive Safety Edges

Configure contact CX or CY (NC), safety input for safety devices such as sensitive safety-edges.

See CX input functions (Function F 2) or CY (Function F 3) in:

- C7 reopening during closing (NC input). When the door is closing, opening the contact causes the door to invert its movement until it is completely open.
- C8 reclosing during opening (NC input). When the door is opening, opening the contact causes the door to invert its movement until it is completely closed.
- r7 reopening during closing (8K2 resistive input). When the door is closing, opening the contact causes the door to invert its movement until it is completely open.
- r8 reclosing during opening (8K2 resistive input). When the door is opening, also opening the contact will cause the door to invert its direction until it completely closes.

 If unused, contacts CX and CY should be deactivated during programming.

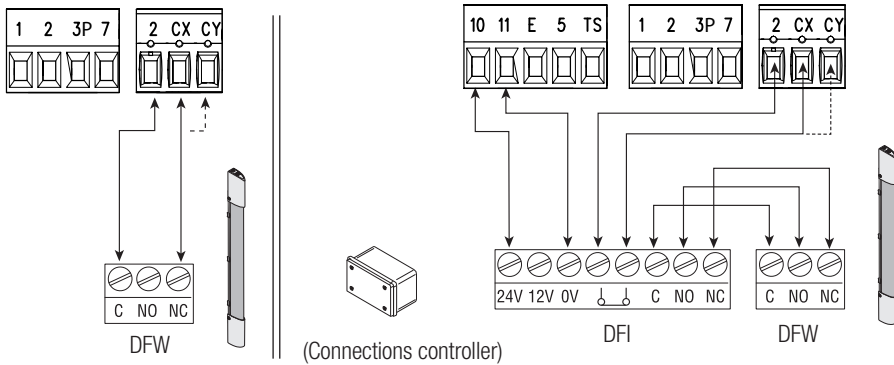

Connecting the safety devices (i.e. the safety test)

At each opening and closing command, the control board checks the efficacy of the safety devices (such as, photocells).

Any malfunction will inhibit all commands and E4 will appear on the display.

Enable function F 5 in programming.

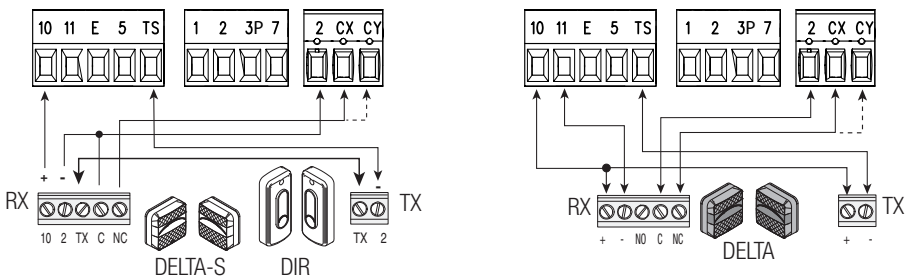

Wireless devices

⚠ Before plugging in the card YOU MUST CUT OFF THE MAINS POWER SUPPLY and, remove any batteries.

Plug the RIOCN8WS card into its corresponding connector on the control board. Set up the function that you are going to associate to the wireless device (F65, F66, F67 e F68). Configure the RIOED8WS, RIOPH8WS and RIOLX8WS wireless devices. Follow the instructions detailed in the installation and accessories' manuals.

📖 If the devices are not configured with the RIOCN8WS card, the display will read out E18.

⚠ If there are any radio-frequency issues, the system's wireless system will inhibit the operator's normal operating mode, and the display will read out the E17 error wording.

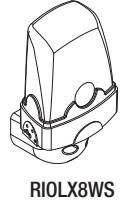
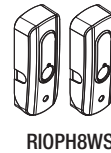
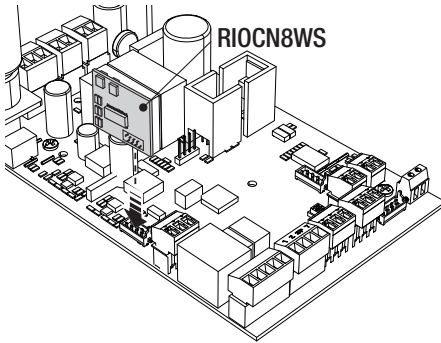

Linking up with Came Remote Protocol(CRP)

⚠ Before plugging in the card YOU MUST CUT OFF THE MAINS POWER SUPPLY and, remove any batteries.
Using the RSE card excludes the local connection with CAME KEY.

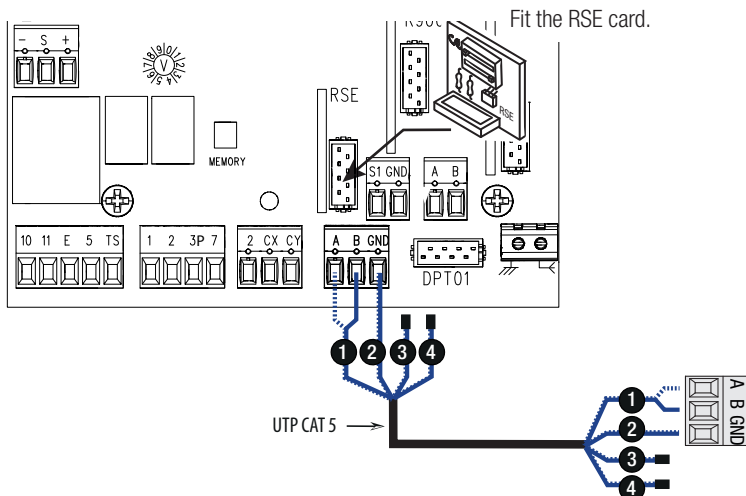

Transmitter and data storage

⚠ Before plugging in the card YOU MUST CUT OFF THE MAINS POWER SUPPLY and, remove any batteries.

To enter, change and delete user or to control the operator via the radio command, fit the AF card.

To save/copy any system settings and registered users, plug in the Memory Roll card.

📖 You must remove the Memory Roll card, after using it.

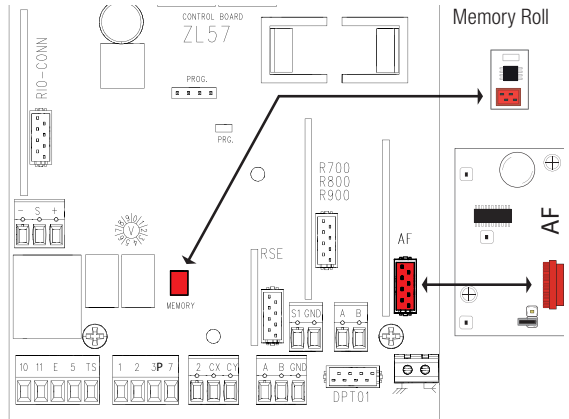

Description of programming commands

Display →

The ESC button is for:

- exiting menus;
- deleting changes;
- commanding a STOP when the motors are in motion.

The ENTER key is for:

- entering menus;
- confirming or memorizing set values.

The < > keys are for:

- moving from one item to another;
- increasing or decreasing a value;
- < CLOSE command;
- > OPEN command.

Browsing the menu

To enter the menu, keep the ENTER key pressed for a few seconds.

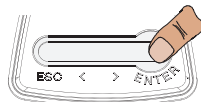



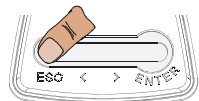



To exit the menu, wait 10 seconds or press ESC.





📖 When the menu is active, the system cannot be used.





Functions menu

-  **IMPORTANT!** Start programming by first performing the **TOTAL STOP (F1)** and **CALIBRATING TRAVEL (A3)** functions
-  Only program functions when the operator is stopped.
-  You can save up to 250 users.

F 1	Total stop [1-2]	<p>NC input – Door stops and excludes any automatic closing; to resume movement, use the control device. The safety device is inserted into [1-2], if unused, select 0.</p> <p>OFF= Deactivated (default) / ON= Activated</p>
F 2	Input [2-CX]	<p>NC input – Can associate: C1 = reopening during closing by photocells, C2 = reclosing during opening by photocells, C3 = partial stop, C4 = obstruction wait, C7 = reopening during closing by sensitive safety-edges, C8 = reclosing during opening by sensitive safety-edges, r7 = reopening during closing for 8K2 resistive, sensitive safety-edges, r8 = reclosing during opening for 8K2 resistive, sensitive safety-edges.</p> <p>OFF = Deactivated (default) / C1 / C2 / C3 / C4 / C7 / C8 / r7 / r8</p> <p> The C3 setting appears only if F19 is active.</p>
F 3	Input [2-CY]	<p>NC input – Can associate: C1 = reopening during closing by photocells, C2 = reclosing during opening by photocells, C3 = partial stop, (appears only if F19 is > 1), C4 = obstruction wait, C7 = reopening during closing by sensitive safety-edges, C8 = reclosing during opening by sensitive safety-edges, r7 = reopening during closing for 8K2 resistive, sensitive safety-edges, r8 = reclosing during opening for 8K2 resistive, sensitive safety-edges.</p> <p>OFF = Deactivated (default) / C1 / C2 / C3 / C4 / C7 / C8 / r7 / r8</p> <p> The C3 setting appears only if F19 is active.</p>
F 5	Safety test	<p>After every opening or closing command, the board will check whether the photocells are working properly.</p> <p>OFF= Deactivated (default) / 1=CX / 2=CY / 4=CX+CY</p>
F 6	Maintained action	<p>The door opens and closes by keeping the button pressed. Opening button on contact 2-3P and closing button on contact 2-7. All other control devices, even radio-based ones, are excluded.</p> <p>OFF= Deactivated (default) / ON= Activated</p>
F 7	Control mode on 2-7	<p>The control device connected to 2-7 performs the step-step command (open-close-invert), sequential (open-stop-close-stop), only open or only close.</p> <p>0 = Step-step (default) / 1 = Sequential / 2 = Open / 3 = Close</p>
F 8	Control mode on 2-3P	<p>The control device connected to 2-3P performs a partial opening (1) or complete opening of the door (2).</p> <p> The partial opening time is adjusted by function F 36.</p> <p>1 = Partial opening (default) / 2 = Open</p>
F 9	Obstruction detection with motor stopped	<p>The door closed, open or after a total stop, the gear motor stay idle if the safety devices, that is, the photocells detect an obstruction.</p> <p>OFF = Deactivated (default) / ON = Activated</p>

F10	Output for state-of-door signal	The LED , connected to 10-5, signals the state of the door. 0 = Steady lit with door open and moving (default) / 1 = Blinks intermittently - every half second, during opening, and - every second, during closing. It stays lit when the door is open and switches off when the door is closed.
F12	Soft Start	Upon each opening or closing command, the door starts slowly for a few seconds. OFF = Deactivated / ON = Activated (default)
F13	Closing thrust	At the closing limit-switch, the gear motor executes a brief closing thrust. OFF = Deactivated (default) / 1 = minimum thrust / 2 = average thrust / 3 = maximum thrust
F14	Sensor type	Setting the type of accessory for controlling the operator. 0 = R700 for control with transponder sensor or magnetic card reader / 1 = R800 for control with the (default) keypad selector
F18	Additional light	Additional light connection output on 10-E. Flashing light: it flashes during the door's opening and closing phases. Cycle: it stays lit from the beginning of the opening until complete closing, including the waiting time before the automatic closing. Courtesy: it stays on for an adjustable time of between 60 and 180 seconds. To set the time, see function F25. 0 = Flashing light (default) / 1 = Cycle / 2 = Courtesy
F19	Automatic Closing Time	The automatic-closing wait starts when the opening limit switch point is reached and can be set to between 1 and 180 seconds. The automatic closing does not work if any of the safety devices trigger when an obstruction is detected, or after a total stop, or during a power outage. OFF = Deactivated (default) / 1 = 1 second /... / 180 = 180 seconds
F20	Automatic closing time after partial opening	The wait before the automatic closing starts after a partial opening command for an adjustable time of between 1 s and 180 s. The automatic closing does not work if any of the safety devices trigger when an obstruction is detected, or after a total stop, or during a power outage.  The F19 function must not be activated. OFF = Deactivated (default) / 1 = 1 second /... / 180 = 180 seconds
F21	Pre-flashing time	Adjusting the pre-flashing time for the flashing light connected to 10-E before each maneuver. The flashing time is adjustable from one to ten seconds. OFF = Deactivated (default) / 1 = 1 second /... / 10 = 10 seconds
F25	Courtesy light time	The courtesy lamp stays lit for the necessary time while the door is opening and closing. It can be set to between 60 and 180 seconds. 60 = 60 seconds /... / 180 = 180 seconds (default)
F28	Speed of opening maneuver	Setting the door's opening speed, calculated as a percentage. 60 = minimum speed /... / 80 = 80% of the maximum speed (default) /... / 100 = maximum speed
F29	Speed of closing maneuver	Setting the door's closing speed, calculated as a percentage. 60 = 60% of the maximum speed /... / 80 = 80% of the maximum speed (default) /... / 100 = 100% of the maximum speed

F30	Slow-down speed	Setting the door's opening and closing slow-down speed, calculated as a percentage. 20 = Minimum speed / 40 = 40% of the motor's speed (default) / 60 = Maximum speed
F33	Calibration speed	Setting the gear motor's calibration speed, calculated as a percentage. 30 = 30% of the maximum speed /... / 50 = 50% of the maximum speed (default) /... / 60 = 60% of the maximum speed
F34	Travel sensitivity	Adjusting obstruction detection sensitivity during door travel. 10 = Maximum sensitivity /... / 100 = Minimum sensitivity (default)
F35	Slow-down sensitivity	Adjusting obstruction detection sensitivity during slow-down. 10 = Maximum sensitivity /... / 100 = Minimum sensitivity (default)
F36	Adjusting the partial opening	Adjusting, as a percentage of total door travel, the door's partial opening. 10 = 10% of the door travel /... / 40 = 40% of the door travel (default) /... / 80 = 80% of the door travel
F41	Adjusting the opening slow-down	Percentage adjustment of the total door travel, of the opening slow-down starting point. 1 = 1% of the door travel / ... / 5 = 5% of the door travel (default) / ... / 60 = 60% of the door travel
F42	Adjusting the closing slow-down	Percentage adjustment of the total door travel, from the closing slow-down starting point. 1 = 1% of the door travel / ... / 15 = 15% of the door travel (default) / ... / 60 = 60% of the door travel
F44	Adjusting the closing approach	Adjusting, as a percentage of the total door travel, of the closing approach starting point. 1 = 1% of the door travel / ... / 10 = 10% of the door travel (default)
F47	Slowed-down start when closing	Adjusting, as a percentage of the total door travel, of the starting of the closing slow-down. OFF = Deactivated / 1 = 1% of the door travel (minimum) / ... / 5 = 5% of the door travel (default) / ... / 50 = 50% of the door travel (maximum)
F49	Managing the serial connection	For enabling the CRP (Came Remote Protocol). 0 = Deactivated / 3 = CRP (default)
F50	Saving data	Saving users and settings saved in the Memory Roll.  This function only appears if a Memory Roll has been plugged into the control board. 0 = Deactivated (default) / 1 = Activated
F51	Uploading data	Uploading data saved in the Memory Roll.  This function only appears if a Memory Roll has been plugged into the control board. 0 = Deactivated (default) / 1 = Activated

F56	Peripheral number	To set the peripheral number from 1 to 255 for each control board when a system is fitted with several operators and features the CRP (Came Remote Protocol) connection system. 1 ----> 255
F63	Changing COM speed	For setting the communication speed used in the CRP (Came Remote Protocol) connection system. 0 = 1200 Baud / 1 = 2400 Baud / 2 = 4800 Baud / 3 = 9600 Baud / 4 = 14400 Baud / 5 = 19200 Baud / 6 = 38400 Baud (default) / 7 = 57600 Baud / 8 = 115200 Baud
F65	Wireless input RIOED8WS [T1]	RIO-EDGE wireless safety-device associated to one of the following available functions: P 7 = reopening during closing, P 8 = reclosing during opening, P 0 = Total stop. For programming, see the instructions that come with the accessory.  This function only appears if the RIOCN8WS card is plugged into the control board. OFF = Deactivated (default) / P0 / P7 / P8
F66	Wireless input RIOED8WS [T2]	RIO-EDGE wireless safety-device associated to one of the following available functions: P 7 = reopening during closing, P 8 = reclosing during opening, P 0 = Total stop. For programming, see the instructions that come with the accessory.  This function only appears if the RIOCN8WS card is plugged into the control board. OFF = Deactivated (default) / P0 / P7 / P8
F67	Wireless input RIOPH8WS [T1]	RIOPH8WS wireless safety-device associated to one of the following available functions: P 1 = reopening during closing; P 2 = reclosing during opening; P 3 = partial stop; P 4 = obstruction wait. For programming, see the instructions that come with the accessory.  This function only appears if the RIOCN8WS card is plugged into the control board. OFF = Deactivated (default) / P1 / P2 / P3 / P4
F68	Wireless input RIOPH8WS [T2]	RIOPH8WS wireless safety-device associated to one of the following available functions: P 1 = reopening during closing; P 2 = reclosing during opening; P 3 = partial stop; P 4 = obstruction wait. For programming, see the instructions that come with the accessory.  This function only appears if the RIOCN8WS card is plugged into the control board. OFF = Deactivated (default) / P1 / P2 / P3 / P4
U1	Entering users	Enter up to 250 users and associate to each of them one of the available functions. This must be done via transmitter or other control device (see "ENTERING USERS WITH ASSOCIATED COMMAND paragraph). 1 = open-close (step-step) / 2 = open-stop-close-stop (sequential) / 3 = only open / 4 = partial opening
U2	Deleting users	Deleting a single user
U3	Deleting users	Deleting all users. OFF = Deactivated / ON = Delete all users

U4	Decoding the radio-frequency code	<p>Select the type of transmitter radio coding that you wish to save on the control board.</p> <p>△ When you select a radio coding, all saved transmitter are automatically deleted.</p> <p>📖 TWIN's coding lets you save multiple users with the same key (Key block).</p> <p>1 = all of the series (default)/2 = only Rolling Code series /3 = only TWIN series</p>
A1	Intended use	<p>Set the intended use.</p> <p>1 = Standard installation</p> <p>📖 The maximum lift is 20 kg beyond the necessary lifting of the window/door.</p> <p>2 = Private installation</p> <p>📖 The maximum lift is 40 kg beyond the necessary lifting of the window/door.</p>
A2	Motor test	<p>Test to verify the gear motor's proper direction of rotation (see the MOTORS TEST paragraph).</p> <p>OFF = Deactivated / ON = Activated</p>
A3	Gate-swing calibration	<p>Automatic calibration of the door travel (see the CALIBRATION DOOR TRAVEL paragraph)</p> <p>OFF = Deactivated / ON = Activated</p>
A4	Resetting parameters	<p>Caution! For restoring the default factory settings and deleting the gate travel setting.</p> <p>OFF = Deactivated / ON = Activated</p>
A5	Maneuver count	<p>For viewing the maneuvers count performed to date by the gear motor (00 = 100 maneuvers; 010 = 1,000 maneuvers; 100 = 10,000 maneuvers; 999 = 99,900 maneuvers; CSI = maintenance job).</p>
A6	Adjusting the motor torque	<p>For adjusting the motor torque from 1 minimum to 5 maximum.</p> <p>1 / 2 / 3 / 4 / 5 (default)</p>
H1	Version	<p>View the firmware version.</p>

List of registered users

Download the LIST OF REGISTERED USERS form from the portal docs.came.com. Enter **L20180423**.

Entering a user with an associated command

N.B.: when entering/deleting users, the numbers displayed in flashing mode, are numbers that are available for other users (max. 250 users).

Caution! Before entering users, unplug any Memory Roll card.

Select U1. Press ENTER to confirm **1**.

Select a command to associate to the user.

The commands are:

1 = step-step (open-close);

2 = - sequential (open-stop-close-stop);

3 = open;

4 = partial opening.

Press ENTER to confirm **2**.

A number between 1 and 250 will blink for a few seconds. This number will be assigned to the user after sending the code via transmitter **3**, keypad **4** or transponder **5**.

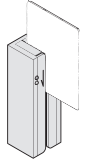
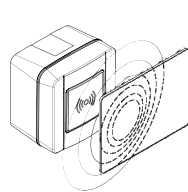
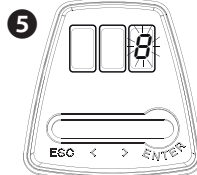
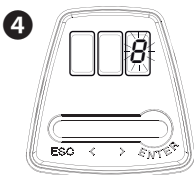
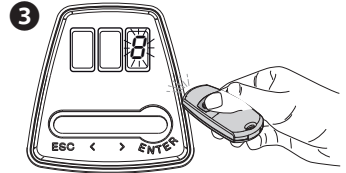
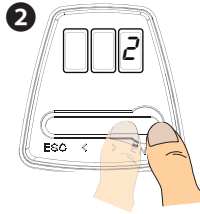
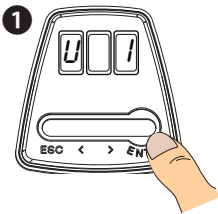

Deleting a single user

1. Select U2. Press ENTER to confirm.
2. Select the user number to delete. Press ENTER to confirm.
3. The Clr wording will appear to confirm the deletion.

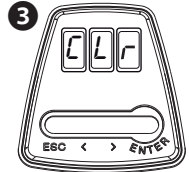
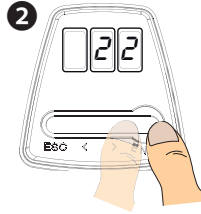
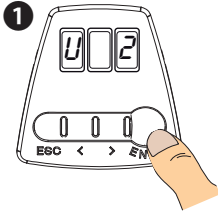

Motor test

1. Select A2. Press ENTER for confirm.
2. Select ON to activate the test. Press ENTER to confirm.
3. The following characters will appear "---" while waiting for the command.

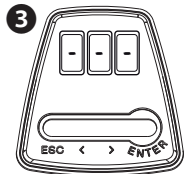
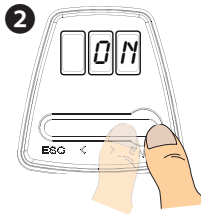
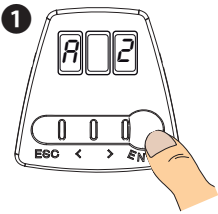

4. Keep the < key pressed and check whether the door closes.
5. Repeat the same procedure with the > arrow to verify whether the door opens.

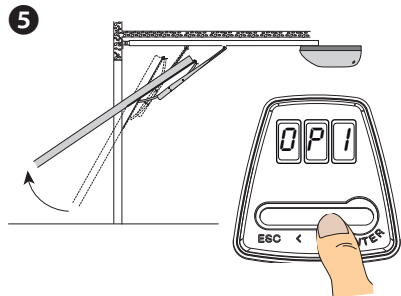
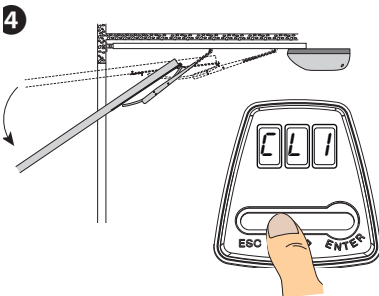

Gate-swing calibration

N.B.: before calibrating the travel, check that the maneuvering area is free of any obstructions.

Important! During the calibration, all safety devices will be disabled except for the PARTIAL STOP one.

Select A3. Press ENTER to confirm **1**.

Select 1 and press ENTER to confirm **2**.

The door will close completely **3**.

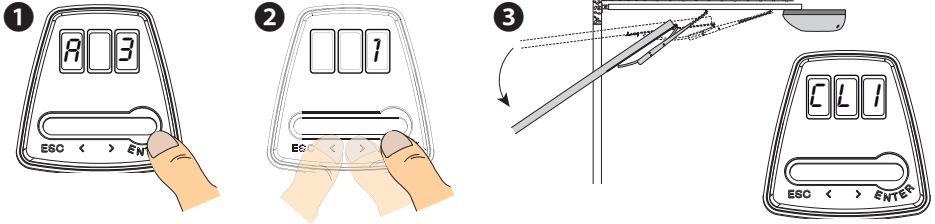

The door will open until it presses and rests against the mechanical stop **4**.

Wait a few seconds to allow the calibration, appearing on the display, to register **5**.

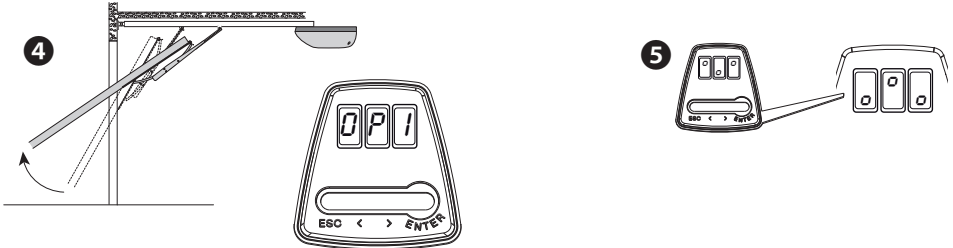

Place the opening mechanical stop against the sliding guide and fasten it.

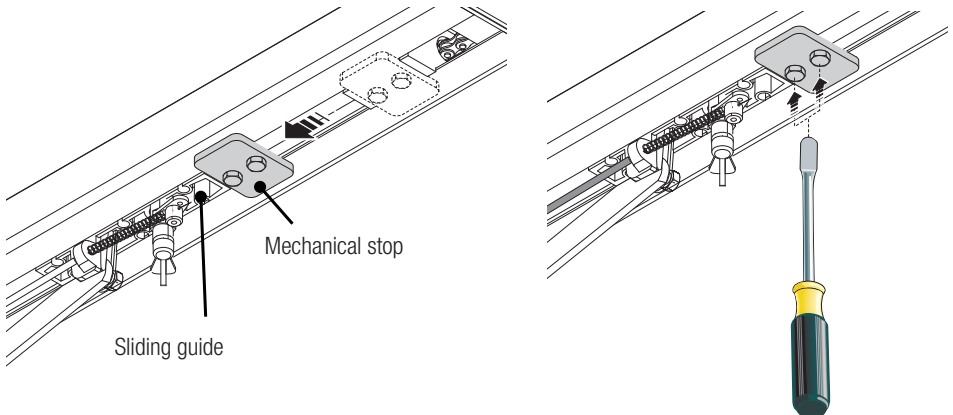

Encoder operation

Obstruction detection when OPENING.
The door recloses.

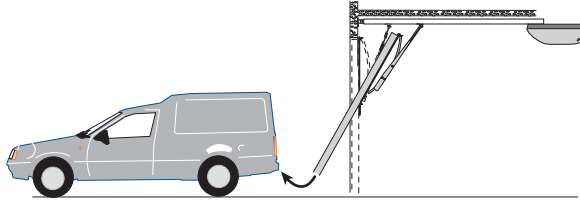

Obstruction detection when CLOSING.

The door inverts its travel direction and reopens.

After two consecutive inversions, when closing, the door stays open and the automatic closing is excluded. After three consecutive detections, when opening and/or closing, the door stops.

To reclose the door, press a control button or use the transmitter.

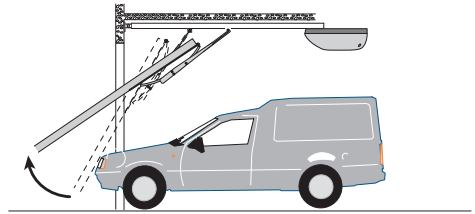
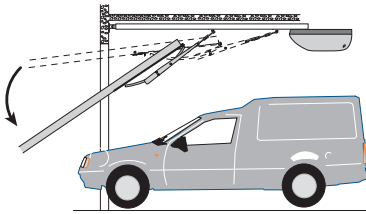

ERROR MESSAGE

 The error messages appear on the display.

E 2	Door-travel calibration incomplete
E 3	Encoder broken
E 4	Services test error
E 7	Operating time error
E 9	Closing obstruction
E11	Maximum number of obstructions consecutively detected
E14	Serial communication error
E15	Transmitter error
E17	Wireless system error
E18	The wireless system configuration is missing

WHAT TO DO IF ...

ISSUES	POSSIBLE CAUSES	POSSIBLE FIXES
The operator opens but will not close	<ul style="list-style-type: none">• Power supply is missing• The gear motor is stuck• The transmitter emits a weak signal or no signal• Button/s and/or selectors stuck	<ul style="list-style-type: none">• Check main power supply• Lock the gear motor• Replace the batteries • Check that the devices and the electric cables are in proper working conditions
The operator opens but will not close.	<ul style="list-style-type: none">• The photocells are working	<ul style="list-style-type: none">• Check that there are no obstructions in the range of operation of the photocells

△ If the problem cannot be solved by following the fixes in the table or if any malfunctions, anomalies, noises, vibrations or suspicious and unexpected behavior is experienced on the system, call for qualified assistance.

FINAL OPERATIONS

Do the final operation only once the connections are complete and the system is started up.

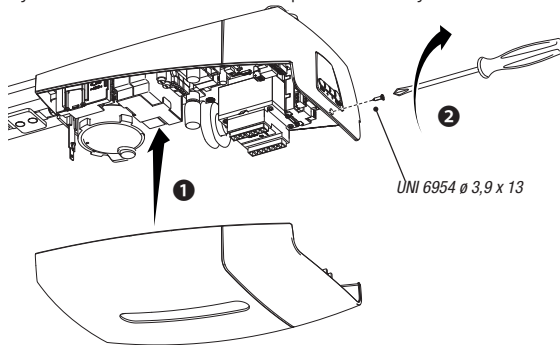

DISMANTLING AND DISPOSAL

 CAME S.p.A. applies a certified Environmental Management System at its premises, which is compliant with the UNI EN ISO 14001 standard to ensure the environment is safeguarded.

Please continue safeguarding the environment. At CAME we consider it one of the fundamentals of our operating and market strategies. Simply follow these brief disposal guidelines:

DISPOSING OF THE PACKAGING

The packaging materials (cardboard, plastic, and so on) should be disposed of as solid household waste, and simply separated from other waste for recycling.

Always make sure you comply with local laws before dismantling and disposing of the product.

DISPOSE OF RESPONSIBLY!

DISMANTLING AND DISPOSAL

Our products are made of various materials. Most of these (aluminum, plastic, iron, electrical cables) are classified as solid household waste. They can be recycled by separating them before dumping at authorized city plants.

Whereas other components (control boards, batteries, transmitters, and so on) may contain hazardous pollutants.

These must therefore be disposed of by authorized, certified professional services.

Before disposing, it is always advisable to check with the specific laws that apply in your area.

DISPOSE OF RESPONSIBLY!

Fabbricante / Manufacturer / Hersteller / Fabricant / Fabricante / Fabricante
/ Wytwórca / Fabrikant

Came S.p.a.

indirizzo / address / adresse / adresse / dirección / endereço / adres / adres
Via Martiri della Libertà 15 - 31030 Dossan di Casier, Treviso - Italy

CAME



DICHIARA CHE LE AUTOMAZIONI PER PORTE GARAGE / DECLARES THAT THE OPERATORS FOR GARAGE DOORS /
ERKLÄRT DASS DIE SCHIEBETÜR - ANTRIEBE / DECLARE QUE LES AUTOMATISMES POUR PORTES DE GARAGE /
DECLARA QUE LAS AUTOMATIZACIONES PARA PUERTAS DE GARAJE / DECLARA QUE AS AUTOMATIZAÇÕES PARA
PORTAS DE GARAGEM / OSWADZKA ZE AUTOMATYKA DO BRAM GARAZOWYCH / VERKLAART DAT DE AUTOMATISER-
INGEN VOOR GARAGEPORTEN

VER13DMS

VER10DMS

SONO CONFORMI ALLE DISPOSIZIONI DELLE SEGUENTI DIRETTIVE / THEY COMPLY WITH THE PROVISIONS OF THE FOLLOW-
ING DIRECTIVES / DEN VORGABEN DER FOLGENDEN RICHTLINIEN ENTSPRECHEN / SONT CONFORMES AUX DISPOSITIONS
DES DIRECTIVES SUIVANTES / CUMPLEN CON LAS DISPOSICIONES DE LAS SIGUIENTES DIRECTIVAS / ESTÃO DE ACORDO
COM AS DISPOSIÇÕES DAS SEQUENTES DIRECTIVAS / SA ZGODNIE Z POSTANOVENJAMI NASTEPUJACYCH DYREKTYW
EUROPEJSKICH / VOLDÖEN AAN DE VOORSCHRIFTEN VAN DE VOLGENDE RICHTLINIEN:

- COMPATIBILITÀ ELETTROMAGNETICA / ELECTROMAGNETIC COMPATIBILITY / ELEKTROMAGNETISCHE
VERTRÄGLICHKEIT / COMPATIBILITÉ ÉLECTROMAGNÉTIQUE / COMPATIBILIDAD ELECTROMAGNETICA / COMPATIBIL-
IDADE ELETROMAGNETICA / KOMPATYBILNOŚCI ELEKTROMAGNETYCZNEJ / ELEKTROMAGNETISCHE COMPATIB-
LITEIT : 2014/30/EU.

Riferimento norme armonizzate ed altre norme tecniche / Refer to
European regulations and other technical regulations / Harmonisierte
Besugnormen und andere technische Vorgaben / Références aux normes
harmonisées et aux autres normes techniques / Referencia normas
armonizadas y otras normas técnicas / Referência de normas harmoniza-
das e outras normas técnicas / Odnozne normy ujednolicono i inne normy
techniczne / Geharmoniseerde en andere technische normen waarnaar is
verwezen

EN 61000-6-1:2008
EN 61000-6-3:2007+A1:2011
EN 62233:2008
EN 60335-1:2012+A11:2014
EN 60335-2-103:2003+A11:2009

RISPETTANO I REQUISITI ESSENZIALI APPLICATI / MEET THE APPLICABLE ESSENTIAL REQUIREMENTS / DEN WESENTLICHEN
ANGEWANDTEN ANFORDERUNGEN ENTSPRECHEN / RESPECTENT LES CONDITIONS REQUISES NECESSAIRES APPLIQUEES /
/ CUMPLEN CON LOS REQUISITOS ESSENCIALES APLICADOS / RESPETAM O REQUISITOS ESSENCIAIS APLICADOS /
SPELNIJA PODSTAWOWE WYMAGANIA WYRLINKI / VOLDÖEN AAN DE TOEPASSABE MINIMUM EISEN:

1.1.3; 1.1.5; 1.2.1; 1.2.2; 1.3.2; 1.3.7; 1.3.8.1; 1.4.1; 1.4.2; 1.5.1; 1.5.6; 1.5.8; 1.5.9; 1.5.9; 1.5.13; 1.6.1; 1.6.3; 1.6.4;
1.7.1; 1.7.2; 1.7.4

PERSONA AUTORIZZATA A COSTITUIRE LA DOCUMENTAZIONE TECNICA PERTINENTE / PERSON AUTHORISED TO COMPIL THE RELEVANT TECHNICAL DOCUMENTATION /
PERSON DIE BEVOLLMÄCHTIGT IST, DIE RELEVANTEN TECHNISCHEN UNTERLAGEN ZUSAMMENZUSTELLEN / DOCUMENTATION TECHNIQUE SPECIFIQUE D'AUTORISATION
A CONSTITUIRE DE / PERSONA FACULTADA PARA ELABORAR LA DOCUMENTACIÓN TÉCNICA PERTINENTE / PESSOA AUTORIZADA A CONSTITUIR A DOCUMENTAÇÃO TÉCNICA
PERTINENTE / OSOBA UPORAWNIANA DO ZREDKOWANAWA DOKUMENTACJI TECHNICZNEJ / DEGENE DIE GEMACHTIGT IS DE RELEVANTE TECHNISCHE DOCUMENTEN
SAMEN TE STELLEN.

CAME S.p.a.

La documentazione tecnica pertinente è stata compilata in conformità all'allegato VIIB. / The pertinent technical documentation has been drawn up in compliance with attached
document VIIB. / Die relevante technische Dokumentation wurde entsprechend der Anlage VIIB ausgestellt. / La documentation technique spécifique a été remplie conformément à
l'annexe VIIB / La documentación técnica pertinente ha sido redactada en cumplimiento con el anexo VIIB. / A documentação técnica pertinente foi preenchida de acordo com o anexo
VIIB. / Odnozna dokumentacja techniczna została zredagowana zgodnie z załącznikiem VIIB. / De technische documentatie terzake is opgesteld in overeenstemming met de bijlage VIIB.

CAME S.p.a. si impegna a trasmettere, in risposta a una richiesta adeguatamente motivata delle autorità nazionali, informazioni pertinenti sulle quasi macchine, e / Came S.p.a., following a
duly motivated request from the national authorities, undertakes to provide information related to the quasi machines, and / Die Firma Came S.p.a. verpflichtet sich auf eine angemessen
motiveerte Anfrage der staatlichen Behörden Informationen über die unvollständigen Maschinen, zu übermitteln, und / Came S.p.a. s'engage a transmettre, en réponse à une demande
bien fondée de la part des autorités nationales, les renseignements relatifs aux quasi machines. / Came S.p.a. se compromete a transmitir, como resposta a una solicitud adecuadamente
fundada por parte de las autoridades nacionales, informaciones relacionadas con las cuasimáquinas / Came S.p.a. compromete-se em transmitir, em resposta a uma solicitação motivada
apropriadamente pelas autoridades nacionais, informações pertinentes às partes que comportam máquinas / Came S.p.a. zobowiązuje się do udzielenia informacji dotyczących maszyn
nieukończonych na odpowiednio uмотовowane prośbie, złożona przez kompetentne organy państwowe / Came S.p.a. verbindt zich ertoe om op met redenen omkleed verzoek van de
nationale autoriteiten de relevante informatie voor de niet voltooide machine te verstrekken.

VIIETA / FORBIDS / VERBIET / INTERDIT / PROHIBE / PROIBE / ZABRANIA SIE / VERBIEDT

la messa in servizio finale la macchina finale in cui deve essere incorporata non è stata dichiarata conforme, se del caso alla 2006/42/CE, / commissioning of the above mentioned until such
moment when the final machine into which they must be incorporated, has been declared compliant, if pertinent, to 2006/42/CE / die Inbetriebnahme bevor die „Endmaschine“ in die de
unvollständige Maschine eingebaut wird, als konform erklärt wurde, gegebenenfalls gemäß der Richtlinie 2006/42/CE. / la mise en service tant que la machine finale dans laquelle elle doit
être incorporée n'a pas été déclarée conforme, le cas échéant, à la norme 2006/42/CE. / la puesta en servicio hasta que la máquina final en la que será incorporada no haya sido declarada
de conformidad de acuerdo a la 2006/42/CE / a colocação em funcionamento, até que a máquina final, onde devem ser incorporadas, não for declarada em conformidade, se de acordo
com a 2006/42/CE. / Urločenie do užívania do zariadenia do času, kedy masyna, do ktorej má byť vstavaný, nie zostane oznámená jako zgodná s vyhláškou 2006/42/ES. Jestli taká
postupová byla konečná, / deze in werking te stellen zolang de eindmachine waarin de niet voltooide machine moet worden ingebouwd in overeenstemming is verklaard, indien toepasselijk
met de richtlijn 2006/42/EG.

Dossan di Casier (TV)
31 Gennaio / January / Januar / Janvier / Enero
/ Janeiro / Styczen / Januari 2018

Legale Rappresentante / Legal Representative / Gesetzlicher
Vertreter / Representant Legal / Representante Legal /
Representante Legal / Prawny Przedstawiciel / Juridische
Vertegenwoordiger

Paolo Menuzzo



Fascicolo tecnico a supporto / Supporting technical dossier / Unterstützung technische Dossier / soutien expédient technique / apoyo expediente
técnico / apoiar dossier técnico / wspieranie dokumentacji technicznej / ondersteunende technische dossier: 001VER13DMS

Came S.p.a.

Via Martiri della Libertà, 15 - 31030 Dossan di Casier - Treviso - Italy - Tel. (+39) 0422 4940 - Fax (+39) 0422 4941
info@came.it - www.came.com

Cap. Soc. 1.610.000,00 € - C.F. e P.I. 03481280265 - VAT IT 03481280265 - REA TV 275359 - Reg Imp. TV 03481280265

DICHIAZIONE DI INCORPORAZIONE allegato / DECLARATION OF INCORPORATION annex / ERKLÄRUNG FÜR DEN
EINBAU anhand / DECLARATION D'INCORPORATION annexe / DECLARACION DE INCORPORACION anexo / DECLARAÇÃO
DE INCORPORAÇÃO anexo / DEKLARACJA WŁADOWNIA załącznik / INBOUWERKLARING bijlage IIB - 2006/42/CE



CAME.COM

CAME S.P.A.

Via Martiri Della Libertà, 15
31030 Dosson di Casier - Treviso - Italy
tel. (+39) 0422 4940 - fax. (+39) 0422 4941